

SCAPE PART TURNER POLE

**SAVE INSTALLATION TIME
AND GUARANTEE THE
HIGHEST LEVEL OF
FLEXIBILITY**

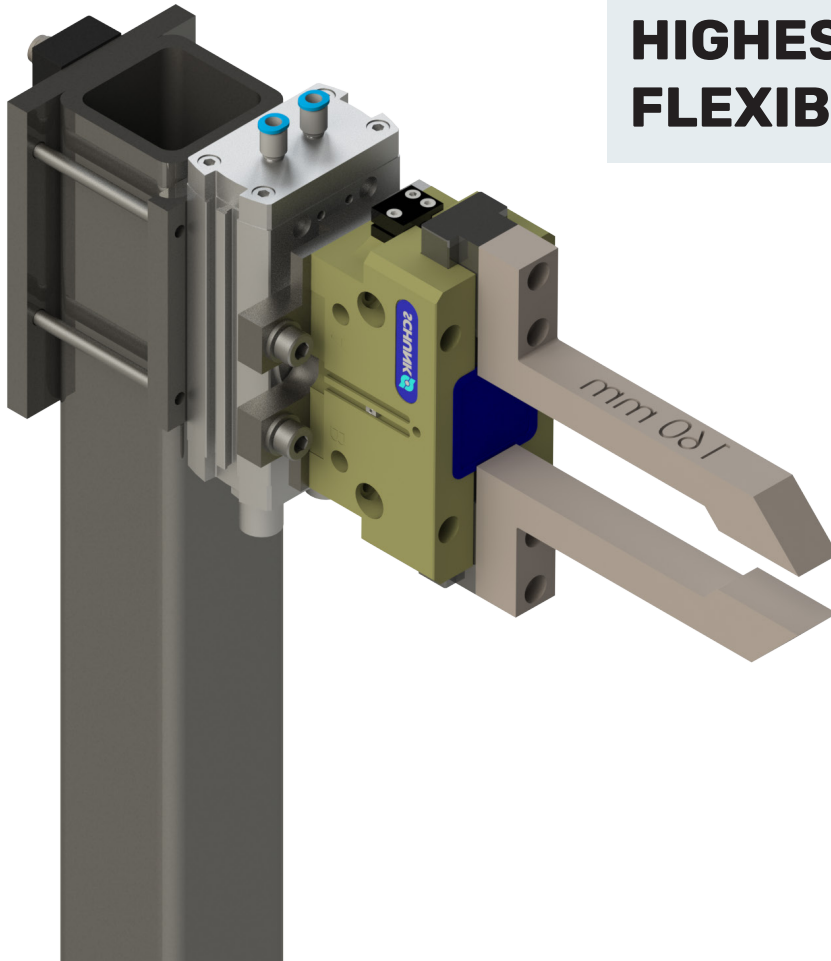

The SCAPE Part Turner™ is specifically designed to be the simplest choice and best option for all SCAPE systems with a requirement for a specific orientation of a part at the final placement. The Part Turner guarantees the highest stability and precision for the SCAPE Bin-Picking System.

Together with the SCAPE 3D Orientation Control and the SCAPE Part Turner, the SCAPE Bin-Picking System offers the highest level of accuracy and precision on the market.

The module can be scaled for your needs and is available as a stand alone Scape product.

WWW.SCAPETECHNOLOGIES.COM

SCAPE

THE BIN-PICKING COMPANY

GENERAL INFORMATION

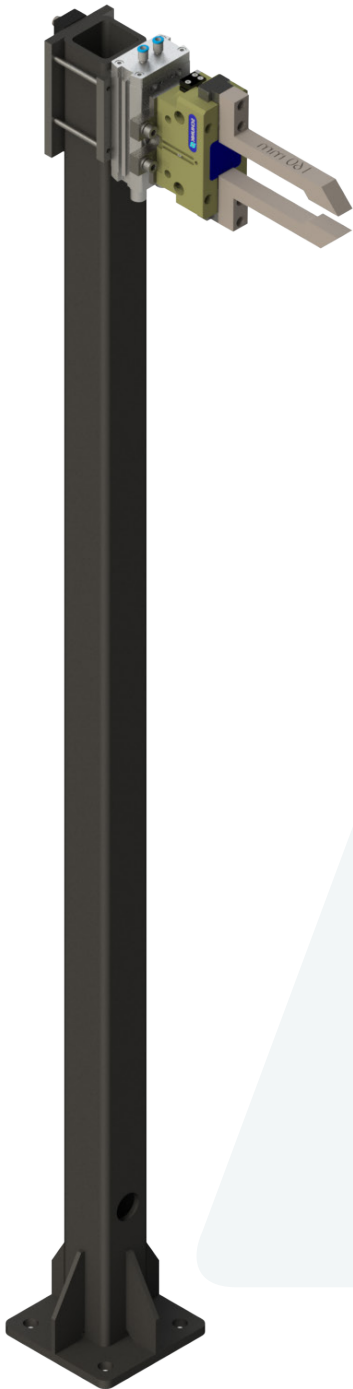

The SCAPE Part Turner is available together with the SCAPE Orientation Control.

It comes in two versions, depending on the weight of the parts, one for up to 1kg and one for up to 3kg. For heavier parts, please contact Scape Technologies directly.

SCAPE Orientation Control ensures the precise and accurate orientation and position of parts after Bin-Picking. With this, SCAPE can handle precision delivery down to the millimetre of any kind of part. SCAPE Orientation Control incorporates AI driven recognition and includes a number of routines for continued bin-picking and error handling.

The SCAPE Part Turner offers even more flexibility for the delivery of parts. Even when parts are gripped by the robot on the wrong side, the Part Turner can quickly turn them, eliminating the need for system stops.

Both the SCAPE Orientation Control and the SCAPE Part Turner can work with a second robot, to shorten cycle times and increase flexibility and accuracy with additional grippers.

(The gripper on the part turner is not included and can be ordered separately from SCAPE)

- ✓ **Standardized for the SCAPE System**
- ✓ **Scalable and Flexible**
- ✓ **Saving Development & Implementation Time**
- ✓ **Reliable and Sturdy Design**